

SI NO S'ESPECIFICA EL CONTRARI, ELS DADES DE PRECISAT INTERIORES HAN DE SER IGUALS AL GRUUP DE LA XAPA. A LES COTES ON NO HI HA TOLERANCIA S'APLICARÀ LA TÀBLA 10090501

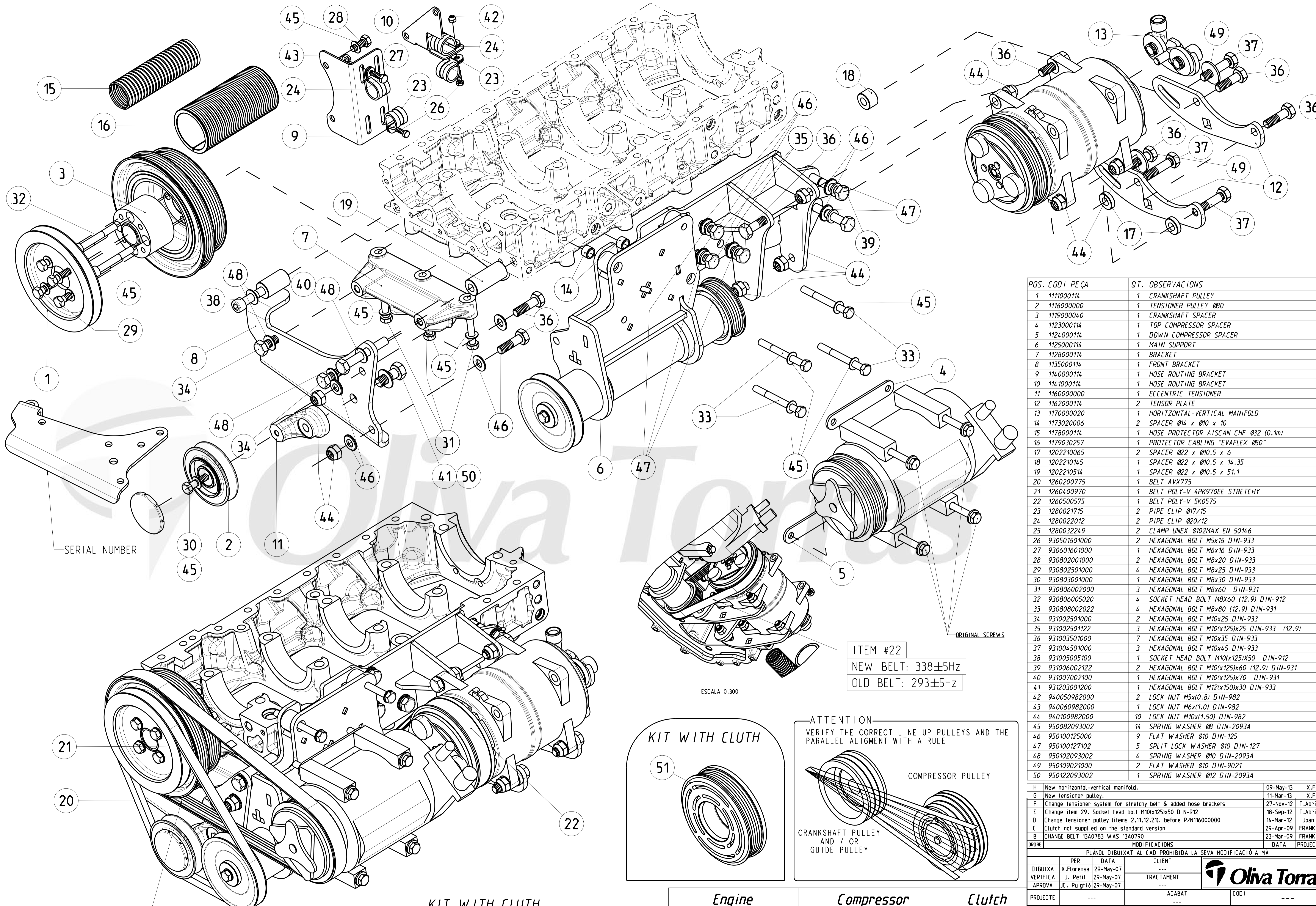

POS.	CODI PEÇA	QT.	OBSERVACIONS
1	1111000114	1	CRANKSHAFT PULLEY
2	1116000000	1	TENSIONER PULLEY Ø80
3	1119000040	1	CRANKSHAFT SPACER
4	1123000114	1	TOP COMPRESSOR SPACER
5	1124000114	1	DOWN COMPRESSOR SPACER
6	1125000114	1	MAIN SUPPORT
7	1128000114	1	BRACKET
8	1135000114	1	FRONT BRACKET
9	1140000114	1	HOSE ROUTING BRACKET
10	1141000114	1	HOSE ROUTING BRACKET
11	1160000000	1	ECCENTRIC TENSIONER
12	1162000114	2	TENSOR PLATE
13	1170000020	1	HORIZONTAL-VERTICAL MANIFOLD
14	1173020006	2	SPACER Ø14 x Ø10 x 10
15	1178000114	1	HOSE PROTECTOR AISCAN CHF Ø32 (0.1m)
16	1179030257	1	PROTECTOR CABLING "EVAFLEX Ø50"
17	1202210065	2	SPACER Ø22 x Ø10.5 x 6
18	1202210145	1	SPACER Ø22 x Ø10.5 x 14.35
19	1202210514	1	SPACER Ø22 x Ø10.5 x 51.1
20	1260200775	1	BELT AVX775
21	1260400970	1	BELT POLY-V 4PK970EE STRETCHY
22	1260500575	1	BELT POLY-V 5K0575
23	1280021715	2	PIPE CLIP Ø17/15
24	1280022012	2	PIPE CLIP Ø20/12
25	1280032249	2	CLAMP UNEX Ø102MAX EN 50146
26	930501601000	2	HEXAGONAL BOLT M5x16 DIN-933
27	930601601000	1	HEXAGONAL BOLT M6x16 DIN-933
28	930802001000	2	HEXAGONAL BOLT M8x20 DIN-933
29	930802501000	4	HEXAGONAL BOLT M8x25 DIN-933
30	930803001000	1	HEXAGONAL BOLT M8x30 DIN-933
31	930806002000	3	HEXAGONAL BOLT M8x60 DIN-931
32	930806005020	4	SOCKET HEAD BOLT M8X60 (12.9) DIN-912
33	930808002022	4	HEXAGONAL BOLT M8x80 (12.9) DIN-931
34	931002501000	2	HEXAGONAL BOLT M10x25 DIN-933
35	931002501122	3	HEXAGONAL BOLT M10(x125)x25 DIN-933 (12.9)
36	931003501000	7	HEXAGONAL BOLT M10x35 DIN-933
37	931004501000	3	HEXAGONAL BOLT M10x45 DIN-933
38	931005005100	1	SOCKET HEAD BOLT M10(x125)x50 DIN-912
39	931006002122	2	HEXAGONAL BOLT M10(x125)x60 (12.9) DIN-931
40	931007002100	1	HEXAGONAL BOLT M10(x125)x70 DIN-931
41	931203001200	1	HEXAGONAL BOLT M12(x150)x30 DIN-933
42	940050982000	2	LOCK NUT M5x(0.8) DIN-982
43	940060982000	1	LOCK NUT M6x(1.0) DIN-982
44	940100982000	10	LOCK NUT M10x(1.50) DIN-982
45	950082093002	14	SPRING WASHER Ø8 DIN-2093A
46	950100125000	9	FLAT WASHER Ø10 DIN-125
47	950100127102	5	SPLIT LOCK WASHER Ø10 DIN-127
48	950102093002	4	SPRING WASHER Ø10 DIN-2093A
49	950109021000	2	FLAT WASHER Ø10 DIN-9021
50	950122093002	1	SPRING WASHER Ø12 DIN-2093A

ORDRE	MODIFICACIONS	DATA	PROJECTAT
H	New horizontal-vertical manifold.	09-May-13	X.F.
G	New tensioner pulley.	11-Mar-13	X.F.
F	Change tensioner system for stretchy belt & added hose brackets	27-Nov-12	T.Abrines
E	Change item 29. Socket head bolt M10(x125)x50 DIN-912	18-Sep-12	T.Abrines
D	Change tensioner pulley (items 2.11.12.21). before P/N116000000	16-Mar-12	Joan P
C	Clutch not supplied on the standard version	29-Apr-09	FRANK V.
B	CHANGE BELT 13A0783 WAS 13A0790	23-Mar-09	FRANK V.

PER	DATA	CLIENT		
DIBUIXA	X.Florensa 29-May-07	---		
VERIFICA	J. Petit 29-May-07	TRACTAMENT		
APROVA	J.C. Puigtió 29-May-07	---		
PROJECTE	---	ACABAT		
MATERIAL	---	---		
DIMENS.	---	PES		
DENOMINACIÓ	FIAT DUCATO 2.3 WITH A/C	ESCALA 0.500	Nº PLÀNOL 1 de 2 REV.: H	
Aquest document és propietat d'Oliva Torras, S.A. quedant prohibida la seva reproducció o cessió, total o parcial, a terceres persones sense autorització prèvia.				

NEW BELT: 191±5Hz
USED BELT: 167±5Hz

POS.	CODI PEÇA	QT.	OBSERVACIONS
51	1112000011	1	COMPRESSOR PULLEY Ø119

Engine	Compressor	Clutch
Ø138 @ 3600 rpm	Ø119 @ 3130 rpm	Without
	Ø119 @ 3130 rpm	With

SI NO S'ESPECIFICA EL CONTRARI, ELS RADIS DE PLEGAT INTERIORS HAN DE SER IGUALS AL GRUIX DE LA XAPA.
A LES COTES ON NO HI HA TOLERÀNCIA S'APLICARÀ LA TÀULA 10090501

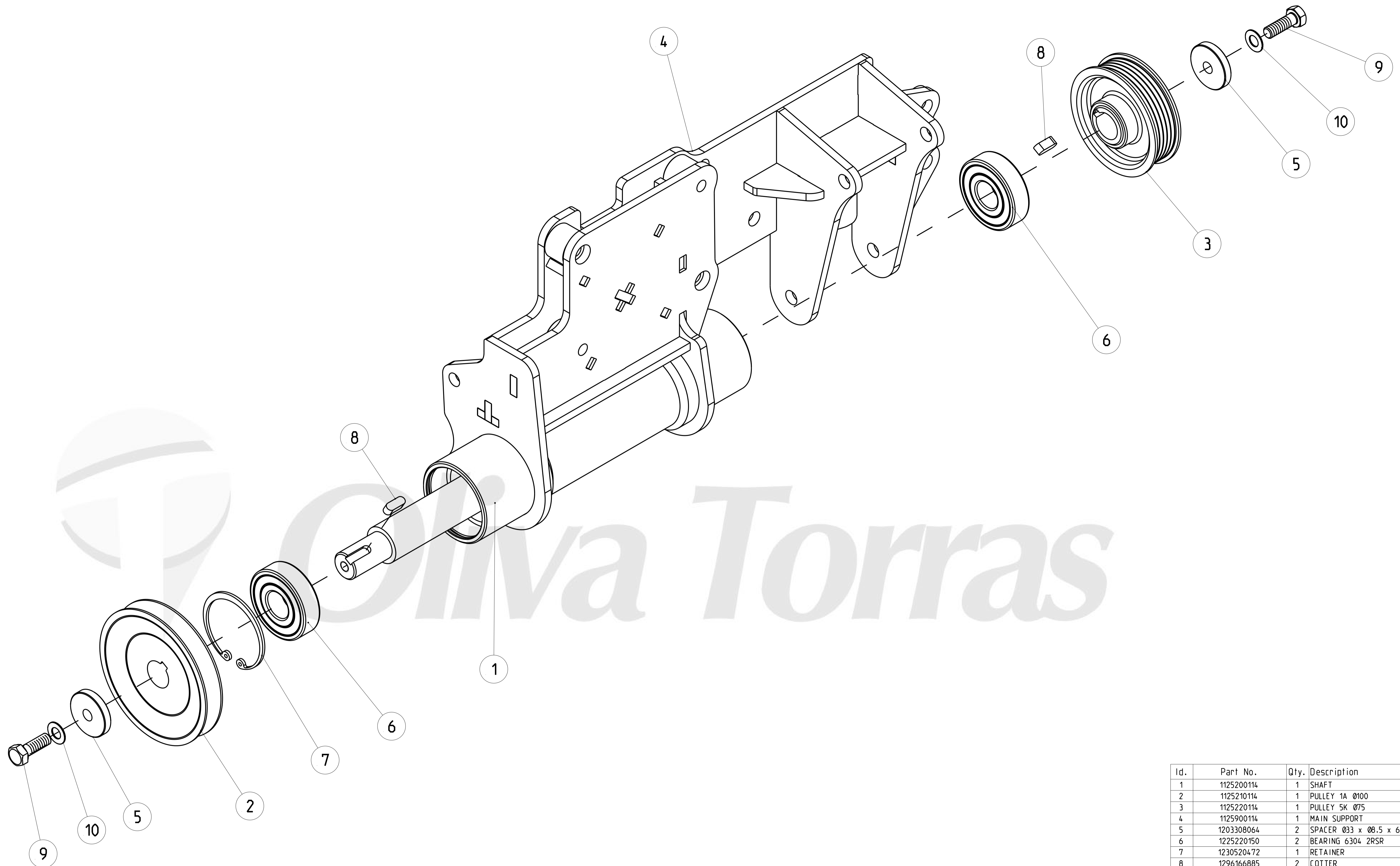

Id.	Part No.	Qty.	Description
1	1125200114	1	SHAFT
2	1125210114	1	PULLEY 1A Ø100
3	1125220114	1	PULLEY 5K Ø75
4	1125900114	1	MAIN SUPPORT
5	1203308064	2	SPACER Ø33 x Ø8.5 x 6
6	1225220150	2	BEARING 6304 2RSR
7	1230520472	1	RETAINER
8	1296166885	2	COTTER
9	930802501020	2	HEXAGONAL BOLT M8x25 DIN-933 (12.9)
10	950082093002	2	SPRING WASHER Ø8 DIN-2093A

ORDRE	MODIFICACIONS	DATA	PROJECTAT

PLÀNOL DIBUIXAT AL CAD PROHIBIDA LA SEVA MODIFICACIÓ A MÀ			
PER	DATA	CLIENT	
DIBUIXA X. Florensa	14-Mar-12	---	
VERIFICA J. Petit	15-Mar-12	TRACTAMENT	
APROVA J.C. Puigtió	15-Mar-12	---	
PROJECTE	---	ACABAT	CODI
MATERIAL	---	---	---
DIMENS.	---	PES	---
DENOMINACIÓ FIAT DUCATO 2.3 WITH A/C		ESCALA 0.500	Nº PLÀNOL 2 de 2 REV.: H
			KC07050114

Aquest document és propietat d'Oliva Torras, S.A. quedant prohibida la seva reproducció o cessió, total o parcial, a terceres persones sense autorització prèvia.